

THIS DRAWING IS UNPUBLISHED. RELEASED FOR PUBLICATION, 19
 © COPYRIGHT 19 BY AMP INCORPORATED. ALL INTERNATIONAL RIGHTS RESERVED.

M	LOC	DIST	P	F	REVISIONS				
					ZONE	LTR	DESCRIPTION	DATE	APPD
-	GP	00				G	REV PER OUE0-0037-01	170CT01	JR

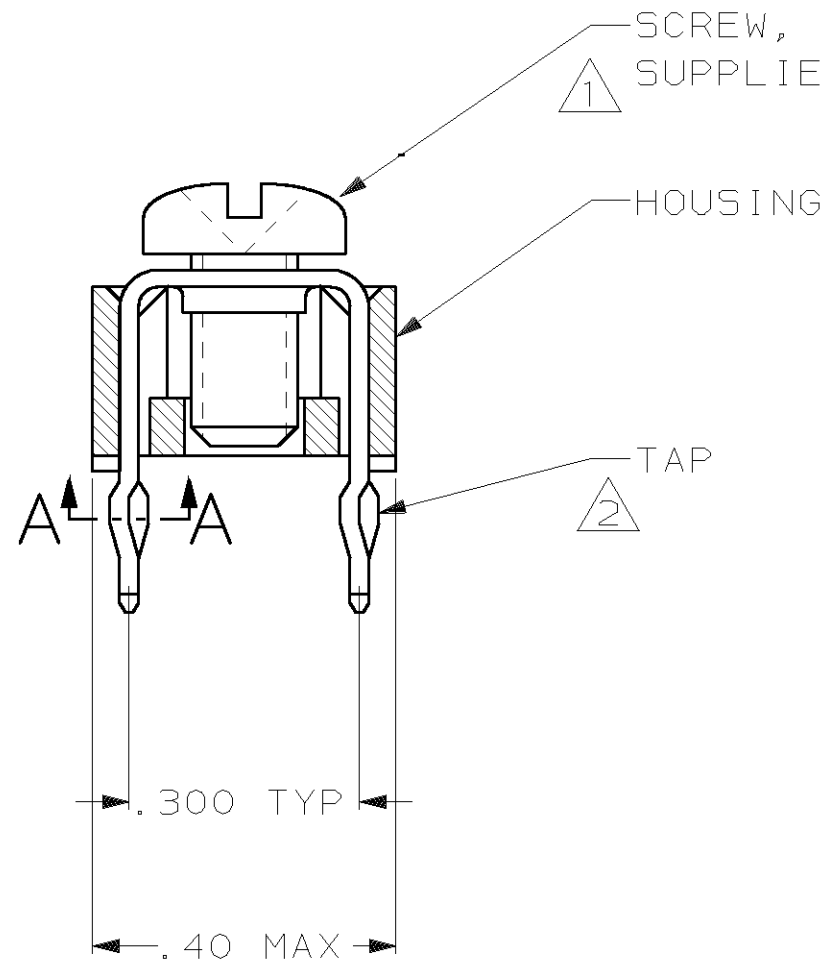
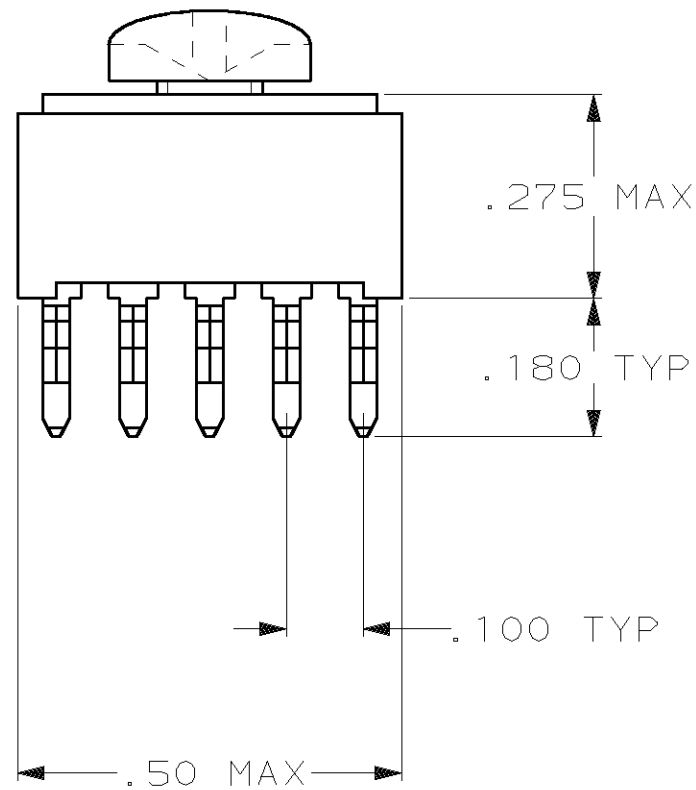

① TO PREVENT THREAD STRIPPING, SCREW TORQUE SHOULD NOT EXCEED 9 IN LBS.
 ② TAP HOLE IS 6-32UNC-2B, TWO MIN THREADS.

.050±.005 DIA

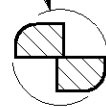

SECTION A-A
 SCALE 10:1
 10 PLACES

	YES	55673-2
SUPSD BY -2	NO	55673-1
	SCREW	PART NO

DO NOT SCALE PRINT. UNLESS SPECIFIED DIMENSIONS IN INCHES TOLERANCES ON: 2 PLC DEC ± _____ 3 PLC DEC ± .010 ANGLES ± _____ MATERIAL HOUSING: NYLON TAP: COPPER ALLOY 725, .025 THICK FINISH TAP: .000150 TIN-LEAD OVER .000050 NICKEL	DR L. BRINER 4/1/97	AMP AMP INCORPORATED Harrisburg, Pa. 17105
	CHK H. JAMSHIDIAN 4/1/97	
	APPD H. JAMSHIDIAN 4/1/97	NAME TAP ASSEMBLY, POWER DISTRIBUTION
	APPD H. JAMSHIDIAN 4/1/97	PRODUCT SPEC _____
APPLICATION SPEC _____	SIZE B FSCM NO 00779 DRAWING NO 55673	
WEIGHT _____	SCALE 4:1 SHEET 1 OF 1	